

## Lab 3 – Measure (30 Minutes)

*Note: (Screenshots below show a white background configuration of your WaveAce to save black ink in printing, this configuration is explained in Lab 2 – VIEW)*

### Overview

The Measure Lab addresses the use of cursors and measure parameters found in modern digital oscilloscopes like the WaveAce.

A **test** at the end of the Lab allows you to check your knowledge.

One of the major advantages of DSOs is their accurate measurement of acquired data using cursors or standard parameters. A variety of cursors are used with your WaveAce instrument. Also the WaveAce oscilloscope offers three varieties of standard parameters — Voltage, Time and Delay.

This lab shows how these cursors and standard parameters can be easily displayed to characterize pulses both vertically and horizontally.

### Goal

Learn how to configure and use:

- Voltage cursors
- Time (Frequency) cursors
- Track cursors
- Standard measure parameters

In this Lab you will learn to use cursors and also to use standard measure parameters for signal characterisation.

### Required Equipment

- 1 x WaveAce passive probe.

### Measuring with Cursors

Cursors are important tools that aid you in measuring signal values. Cursors are markers (lines or cross-hairs) that you can move around the grid or the waveform itself. Use cursors to make fast, accurate measurements and to eliminate guesswork. There are three basic types:

- Voltage (Vertical) cursors are dashed lines that you move vertically on the grid to measure the voltage levels of a signal. When used on a FFT waveform dBV values are measured.
- Time (Horizontal) cursors are dashed lines that you move horizontally on the grid to measure the time values of a signal. When used on a FFT waveform frequency values are measured.
- Track (Horizontal) cursors are cross-hairs that you move horizontally along any channel waveform. Place them at a desired locations along the time axis to read the signal's voltage levels at the selected times.

## Setup

Connect the probe to Channel 2 and the probe top to the calibrator (CAL) output loop on the front panel. Use the sprung hook accessory of the probe to clip to the CAL output loop.

## Step 1

Reset the scope configuration to the default factory settings using the front panel DEFAULT SETUP button. An alternative method is to use the front panel SAVE/RECALL button, then press the Type button until Factory is displayed and finally press the Load button.

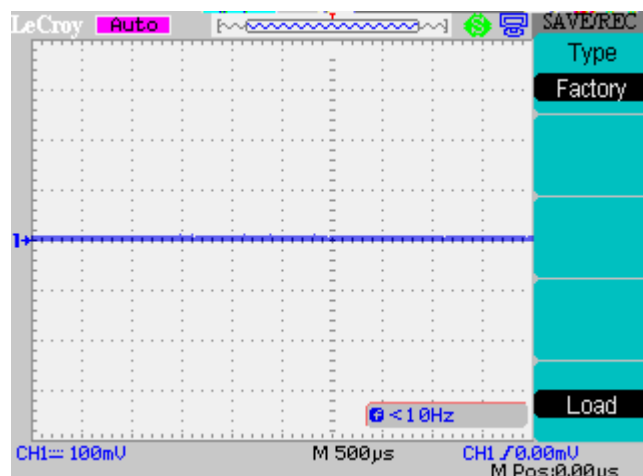

At any time the menu on the right-hand side of the screen can be removed/restored by pressing the front panel MENU ON/OFF button.

## Step 2

Turn CH1 off and CH2 on by pressing the front panel CH1 and CH2 buttons. Pressing a channel button also displays the corresponding vertical settings. DC coupling on CH2 is selected by default. Check the slider switch on the probe is set to X10 and using the Probe button set 10X on the screen.

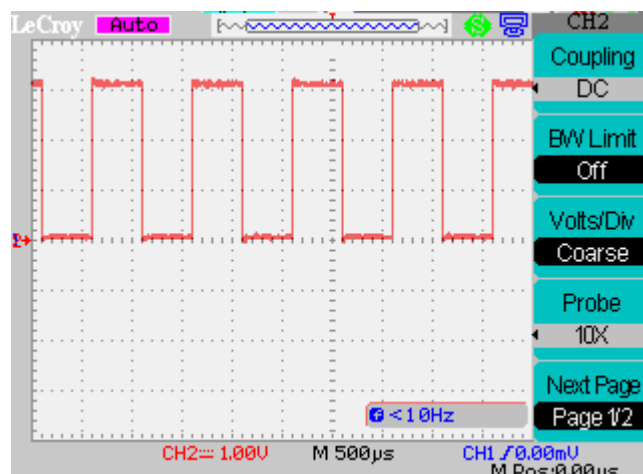

## Step 3

Press the [blue] AUTO button on the front panel. In a few seconds you should have a triggered signal with a number of cycles shown on the screen.

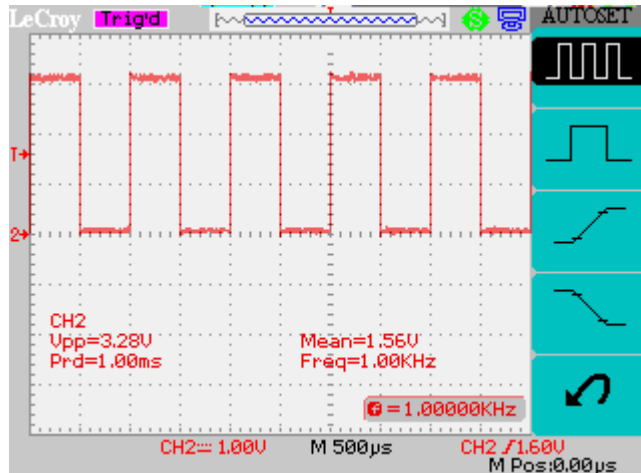

## Step 4

Notes: Pressing RUN/STOP is a smooth way of stopping the scope to allow measurement of the waveform captured on screen.

The side menu can be turned off using the MENU ON/OFF button or by selecting a finite time for the Menu Display in the DISPLAY menu.

Turn the Horizontal knob to adjust the Timebase. Fill the screen with a period of the signal. Press RUN/STOP to stop the acquisition.

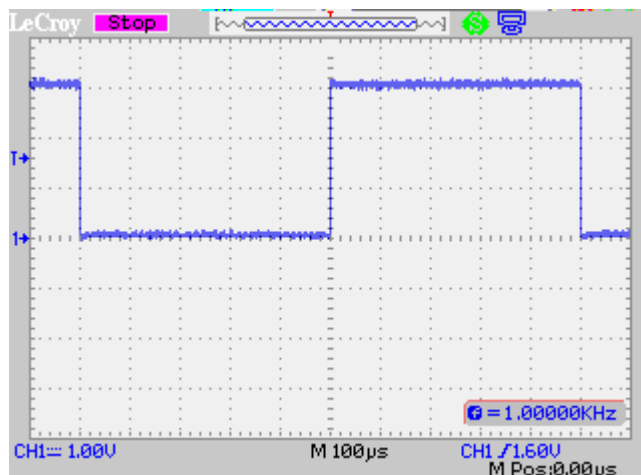

## Step 5

Turn on Cursors by pressing the CURSORS button. In the menu select Manual Mode. For Type choose Voltage and for Source choose CH1. Select Cur A to use the Intensity/Adjust knob for adjusting CurA and select Cur B to use the Intensity/Adjust knob for adjusting CurB.

## Step 6

Notes: Vertical cursors are moved pixel by pixel up and down the grid. Both cursors use the same source which can be any of the waveforms.

Position one cursor on top and the other to the bottom of the signal and measure the amplitude of the signal

Here the difference in

amplitude between the minimum and maximum levels of the square wave and the individual voltage levels are shown in the top corner of the display.

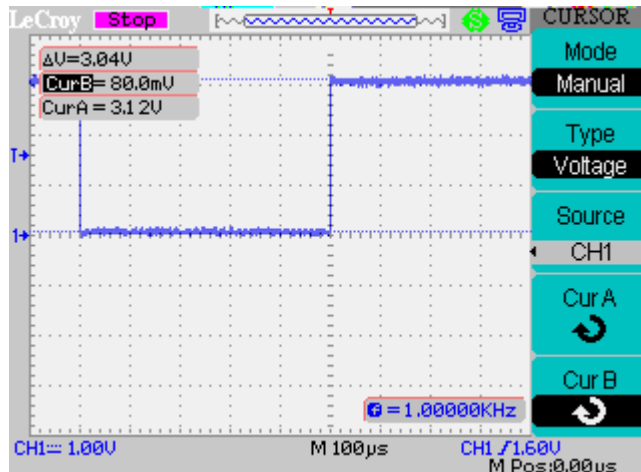

## Step 7

Notes: Horizontal cursors are moved pixel by pixel across the grid. Both cursors use the same source which can be any of the waveforms.

Here the difference in time between the start and end of the square wave, its inverse and the individual times are shown in the top corner of the display.

The time reference ( $t=0$ ) is the trigger point (indicated by the small red vertical arrow on the top line of the screen).

In the CURSOR menu change Type to Time. Select each cursor in turn and adjust to measure one complete cycle of the waveform. Turn off the menu to see the second falling edge.

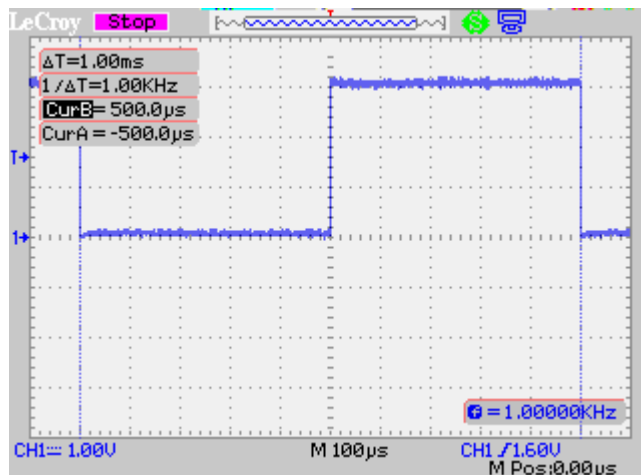

## Step 8

Notes: Track cursors are moved to any point along the trace and can be used to measure time and voltage. Each cursor can use CH1, CH2 or NONE as the source. Selecting NONE turns off the corresponding cursor.

The Track Cursor is a cross-

Press RUN/STOP to switch back to continuous triggering. Now select a timebase of 1us/div. In the CURSOR menu change Mode to Track. Now two cross-hair cursors are displayed. Select each cursor in turn and adjust to measure rising edge of the waveform.

hair marker. When the cross-hairs are placed on a data point, they change as the data changes. All time and voltage values are displayed in the top corner of the display.

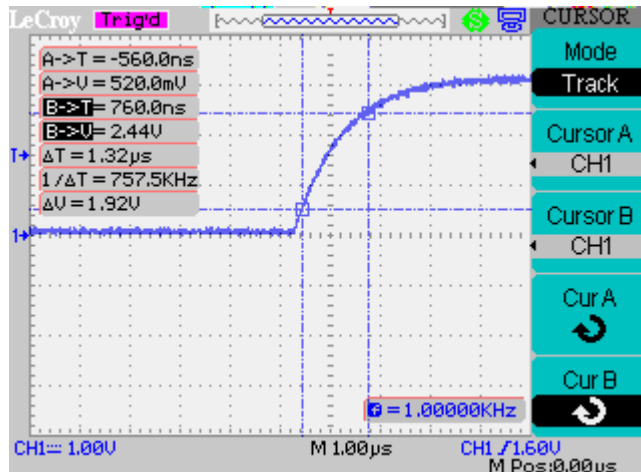

## Step 9

*Notes: Parameters are pre-programmed measurements that eliminate the need to set up cursors or standardised measurements, like rise-time, fall-time, peak-peak amplitude etc. Use them to automatically calculate many attributes of your channel waveforms. You can display up to five selected parameter measurements on the side menu.*

*Either CH1 or CH2 can be used as the source for each of the Voltage and Time measurements. For Delay measurements both channels are required and the source setting is ignored.*

*Remember to turn on the source channel(s).*

In the CURSOR menu change Mode to Auto. For the moment nothing is displayed. This is because in Auto mode the cursors operate in combination with a measurement parameters.

Change the timebase to 500us/div and press the MEASURE button.

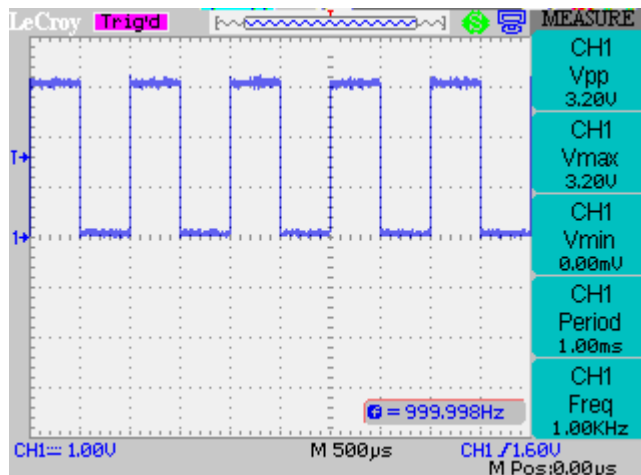

To change any measurement press the corresponding button (in this case the top button).

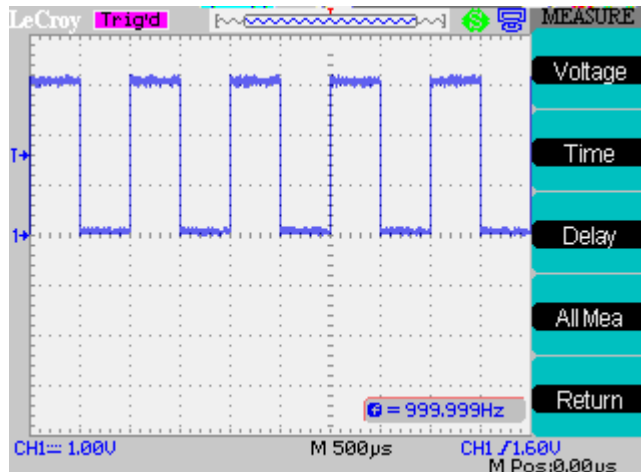

Now select the Voltage group, then Type and scroll to Mean. Leave the Source as CH1. In cases where more than one trace is in use the source can be changed if required. Because we previously selected cursor mode as AUTO a cursor corresponding to the Mean value is displayed.

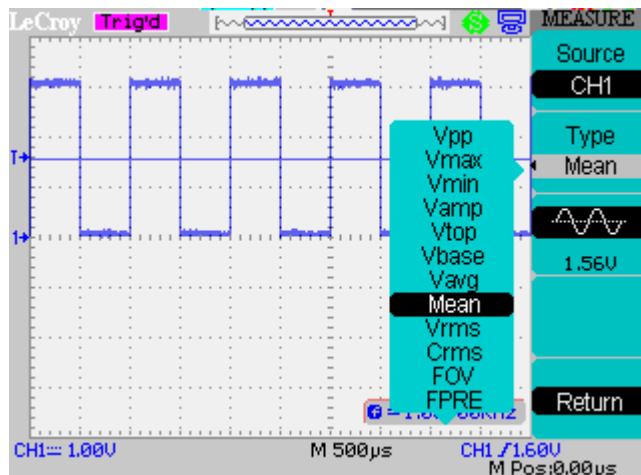

Press the front panel MEASURE button and your selected measurement is now shown (CH1 Vpp has been replaced by CH1 Mean).

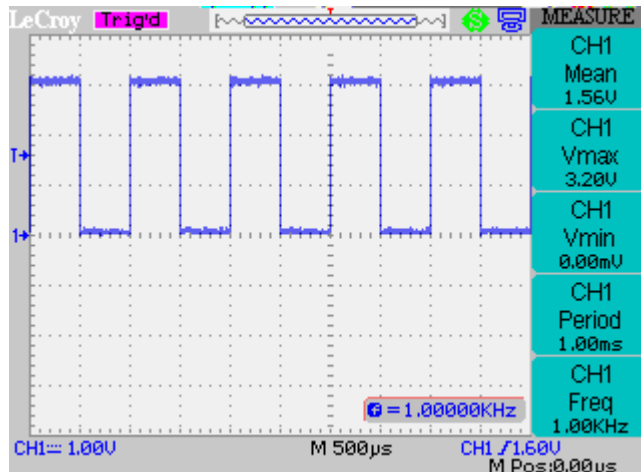

## Step 10

*Note: Measurements groups are displayed on the screen.*

*Either CH1 or CH2 can be used as the common source for all the Voltage and Time measurements. For Delay measurements both channels are required and the source setting is ignored.*

*Remember to turn on the source channel(s).*

*Where the measurement can not be calculated \*\*\*\* is displayed in place of the value.*

Sometimes more than five measurements are required. Complete measurement groups can be displayed on the screen. In the second screenshot in Step 9 note there is a menu item called All Mea. Press the corresponding button and then select the Voltage and Time groups.

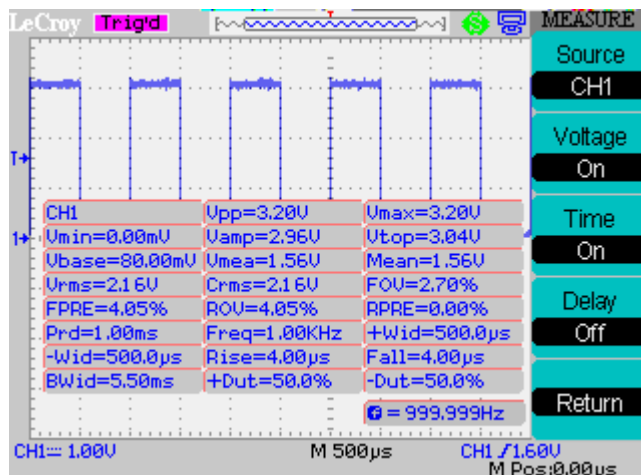

## Test

### Question 1

What are the four cursor modes in the WaveAce instrument?

.....  
.....  
.....  
.....

What are the two cursor types additionally available in ..... mode?

.....  
.....

### Question 2

What does it mean if the measured period (Prd) is displayed as \*\*\*\* and what would you need to do to get a value?

.....  
.....

### Question 3

Whilst setting up a measurement on the side menu you notice that cursors are suddenly displayed. Explain why?

.....  
.....

### Summary

In this lab you learned the different types of cursors in the WaveAce instrument and how to use them for measuring signal parameters. You also learned how to setup and use signal parameters.